

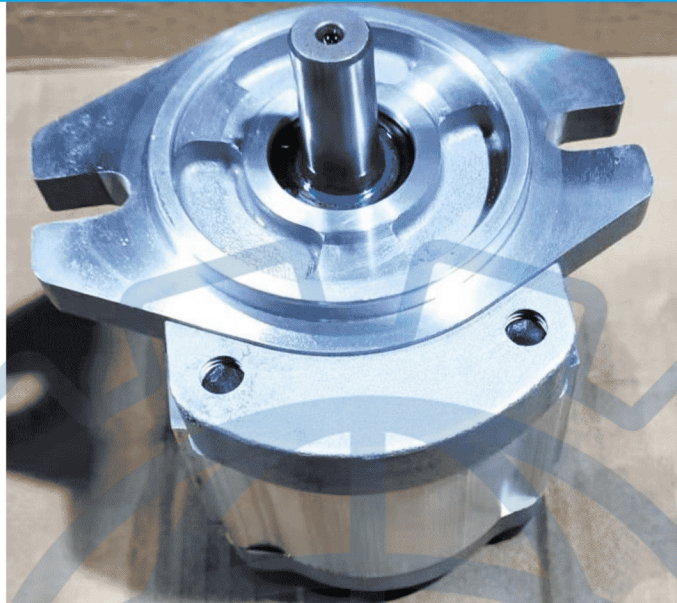

## CBT-F4 Gear Pump



### 产品特点 Technical Features

- ★ High strength aluminum alloy housing
- ★ The connection form of input shaft includes flat key, rectangle spline and flat end
- ★ The connection form of oil inlet and oil outlet has options of screw and flange
- ★ The automatic compensation mechanism of axial clearance gear pump to maintain a long-time high efficiency work
- ★ With high working pressure and wide speed range, it can maintain high volume efficiency even at a slow speed of 600rpm

### 描述 Ordering Code

**CBT E - 4 20 - A E P L**

转向Rotation

L: 左转Left (Counterclockwise)  
R: 右转Right (Clockwise is omitted)

轴伸形式Shaft end

P: 平键plain key ; H: 矩形花键Rectangle spline ;  
Φ: SAE花键SAE spline ; X: 渐开线花键Involute spline

油口形式Joining Port

F: 法兰Flange L: 螺纹Screw

安装形式Mounting 菱形安装A: Oval

公称排量Nominal displacement ml/r

齿轮模数m=4 Gear modulus m=4

额定压力Pressure grade E:16Mpa; F: 20MPa

产品代号Product code



外形尺寸 Outline Dimension

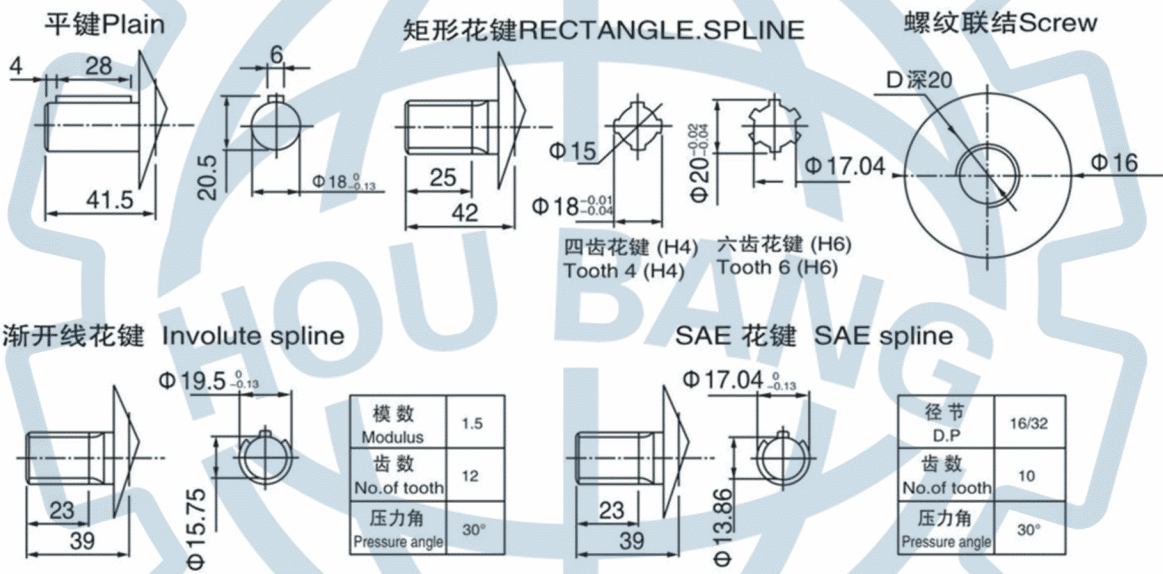
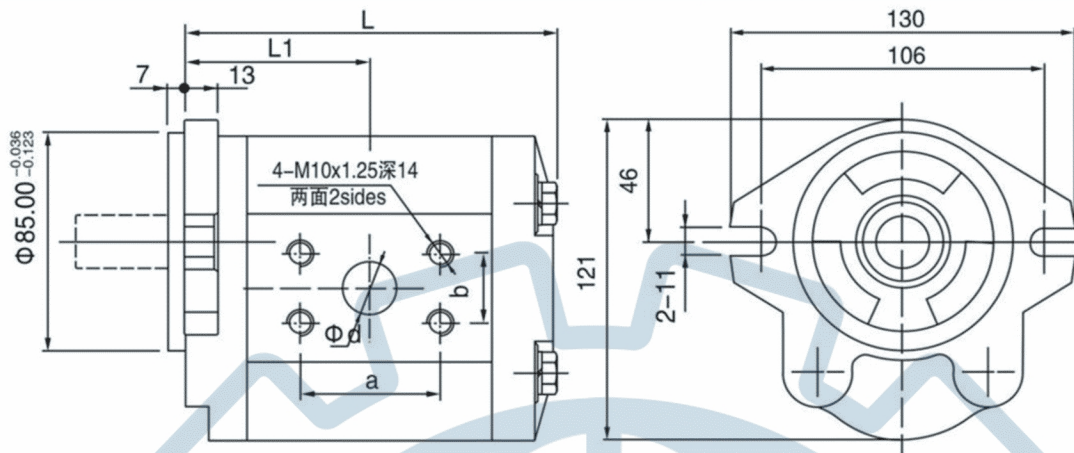

产品参数 Specification

型号 Model	理论排量 Nominal displacement (ml/r)	压力 Pressure (bar)		转速 Speed (r/min)			容积效率 Volumetric efficiency (≥%)	重量 Weight (kg)
		额定 Rated.	最高 Max.	最低 Min.	额定 Rated.	最高 Max.		
CBT-F410-A***	10	200	250	600	2500	3000	92	3.1
CBT-F412.5-A***	12.5							3.2
CBT-F414-A***	14							3.3
CBT-F416-A***	16							3.4
CBT-F419.2-A***	19.2							3.5
CBT-F420-A***	20							3.6
CBT-F423-A***	23							3.7



描述 Outline Dimension

型号 Model	理论排量 Nominal displacement (ml/r)	压力 Pressure (bar)		转速 Speed (r/min)			容积效率 Volumetric efficiency (≥%)	重量 Weight (kg)
		额定 Rated.	最高 Max.	最低 Min.	额定 Rated.	最高 Max.		
CBT-F425-A***	25	200	250	600	2500	3000	92	3.7
CBT-F426.5-A***	26.5							3.8
CBT-F430-A***	30							3.9
CBT-F432-A***	32							4.0

型号 Model	L1	L	螺纹连接 Screw		法兰连接 Flange					
			D		进油口 Inlet			出油口 Outlet		
			进油口 Inlet	出油口 Outlet	d	a	b	d	a	b
CBT-F410-A***	57	116	M22×1.5 铤平φ50	M18×1.5 铤平φ45	23	47.6	22.2	20	47.6	22.2
CBT-F412.5-A***	58.3	118								
CBT-F414-A***	59.3	120								
CBT-F416-A***	60.3	122								
CBT-F419.2-A***	61.8	125	M33×2 铤平φ50	M27×2 铤平φ45	26	52.4	26.2	20	47.6	22.2
CBT-F420-A***	62.5	127								
CBT-F423-A***	64	130								
CBT-F425-A***	65.8	133								
CBT-F426.5-A***										
CBT-F430-A***	67.8	133								
CBT-F432-A***	69.5	141								