



LBZ Gear Pump 's Motor Device



Introduction

LBZ vertical gear pump motor device is suitable for lubrication oil station as oil, hydraulic drive system can also be used as a power source, gear pumps conveying non-corrosive lubricating liquid medium, the viscosity of the medium is suitable for industrial lubricants N22-N460's or hydraulic temperature $50\text{ }^{\circ}\text{C} \pm 5\text{ }^{\circ}\text{C}$.

Dimension

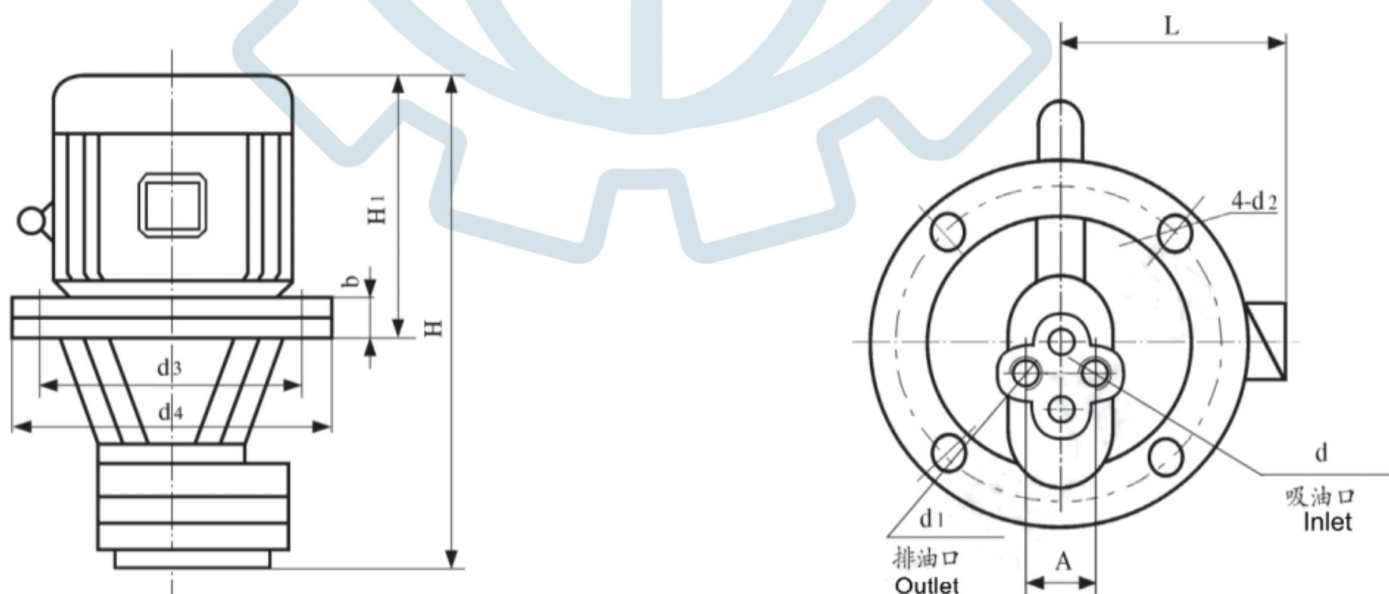



Technical Specification

Model	d	d1	d2	d3	d4	A	b	L	H	H1
LBZ-6	Z3/8"	Z3/8"	11	165	200	35	30	140	423	275
LBZ-10									435	
LBZ-16	Z3/4"	Z3/4"	11	165	200	50	30	140	474	293
LBZ-25									482	
LBZ-40	Z1"	Z3/4"	13	215	250	55	32	155	520	328
LBZ-63									532	
LBZ-100	Z1 1/4"	Z1"	13	215	250	65	32	180	606	363
LBZ-125									615	
LBZ-160	Z2"	Z1 1/2"	15	265	300	96	38	210	656	415

